

General Description



Description

Safety switches have a number of applications from service entrance to branch circuit protection. They are also horsepower rated for use as motor circuit switches. The Application Guide table, below, summarizes major differences and similarities between the Heavy Duty and General Duty type of Cutler-Hammer Safety Switches.

Individual catalog pages and selection tables provide more specific information as to number of poles, voltage, specifications and horsepower ratings.

K-Series Switch Design^①

The efficient K-series design utilizes double-break, rotary blade action for high performance and reliability. Here are some of the characteristics of the K-Series type of switch:

- High visibility handle and nameplate for indication of switch position — ON or OFF.

- Clear line terminal shields.
- Unique Control Pole option — visible blade and positive action electrical interlocking.
- Generous wiring room — meeting or exceeding NEC wire bending space, even with field installed crimp lugs.
- Built-in Fuse Pullers in Type 4 and 12 enclosed switches.
- Side hinged Type 3R enclosure doors.
- Tangential knockouts in Type 1 and 3R enclosures through 200A size DH.
- Stainless steel enclosures for UL Type 4X applications — Dust-tight, Watertight and Corrosion Resistant.
- Type 12 enclosures for 30-200A switches also rated for 3R use when a factory provided drain hole is opened.
- Rated for 60°/75°C wire connection.

Safety Switch Application Guide — See Catalog Selection Tables for specific ratings.

Application/Features	Type DG General Duty Safety Switches	Type DH Heavy Duty Safety Switches
Type of Facility	Residential, Commercial, Light Industrial	Commercial, Institutional, Industrial
Maximum Voltages	240V ac — 250V dc in larger sizes	600V ac — 250V dc and 600V dc
Short Circuit Rating for Non-fused Switches	10,000 rms symmetrical amperes	10,000 rms symmetrical amperes
Short Circuit Rating with Standard Fuse Clips	With Class H fuse clips — 10,000 rms symmetrical amperes	Switches with Class H fuse clips — 10,000 rms amperes 800-1200A switches with Class L fusing — 200,000 rms
Short Circuit Rating with Fuse Options	Class R fuse adaptation and 400-600A switches with T or J fuse adaptation — 100,000 rms amperes	Switches with Class R or Class J fusing and 200-800A switches with Class T fuse adaptation — 200,000A at 480V and 100,000 rms sym. amperes at 600V
Ampere Sizes	30, 60, 100, 200, 400, 600	30, 60, 100, 200, 400, 600, 800, 1200
Maximum Horsepower Ratings	200 hp at 240V ac	250 Hp at 240V, 500 Hp at 480 and 600V ac
UL (NEMA) Enclosure Types	Type 1 — General purpose indoor use Type 3R — Rainproof and Sleet-Resistant	Type 1 Indoor, 3R Outdoor Type 4 Watertight and Dust-tight Type 4X Watertight, Dust-tight and Corrosion Resistant Type 12 Indoor falling dust, dirt and liquids Type 12/3R convertible to outdoor use
Terminals	Box Lug (screw pressure) for Al/Cu wire	Box Lug (screw pressure) for Al/Cu wire
Elec. Interlock — Snap-switch Type	Field Installed Kit, 200-600A sizes	Field or Factory Installed for all sizes
Control Pole Interlock	Field Installed Kit, 400-600A sizes	Field Installed for K-Series Switches
Fuse Pullers	Not Available	Standard in Type 4 and 12 enclosed switches Field Installed for all other 30-200A switches

^① K-Series design available where the letter K appears in the catalog number.

Further Information

CAT.73.01.T.E



Selection Guide

Safety Switch Selection Guide

Type	Fuse Type	Fuse Class	Ampere Rating	Number of Poles	Enclosure Types							
					NEMA 1	NEMA 3R	NEMA 12	NEMA 4 Painted Steel	NEMA 4X Stainless Steel	NEMA 4X Non-Metallic		
Air Conditioning Disconnect Residential/Commercial/ Air Conditioning/ Heat Pump Disconnects	Max. 240 Vac Fusible	Cartridge	H	30 and 60	2	—	YES①	—	—	—	—	
	Non-Fusible	—	—	60	2	—	YES①	—	—	—	—	
General Duty	Single Throw Max. 240 Vac Horsepower Rated	Fusible	Plug	—	30	1 and 2	YES	YES	—	—	—	
		Cartridge	H	30-600	2 and 3	YES	YES	—	—	—	—	
Heavy Duty	Single Throw Max. 600 Vac Horsepower Rated	Fusible	Cartridge	H	30-600	2, 3 and 4	YES Up to 1200A	YES Up to 1200A	YES② Up to 800A	YES 400-800A	YES Up to 800A	YES Up to 200A
		Non-Fusible	—	—	30-1200	2, 3 and 4	YES	YES	YES② Up to 800A	YES 400-800A	YES Up to 800A	YES Up to 200A
6-Pole Motor Circuit	Single Throw Max. 600 Vac	Fusible	Cartridge	H	30-200	6	—	YES	—	—	—	
		Non-Fusible	—	—	30-200	6	—	YES	YES	—	—	
Double Throw	Max. 600 Vac Horsepower Rated	Fusible	Cartridge	H T (600V) T (240V)	30-400 400 600	2 and 3	YES Up to 600A	YES Up to 200A	—	—	—	
		Non-Fusible	—	—	30-800	2, 3, 4 and 6	YES	YES	YES Up to 400A	—	YES Up to 400A	—
Rotary Switches	Max. 600 Vac	Non-Fusible	—	—	40-100	3, 4	YES	YES②	YES②	—	YES	

EnviroLine	Fuse Type		Fuse Class	Ampere Rating	Number of Poles	Enclosure Types					
						NEMA 1	NEMA 3R	NEMA 12	NEMA 4 Painted Steel	NEMA 4X Stainless Steel	NEMA 4X Non-Metallic
All Stainless	Fusible	Cartridge	H	30-400	2 and 3	—	—	—	—	—	—
	Non-Fusible	—	—	30-400	3	—	—	—	—	—	—
Viewing Window Upper and Lower	Fusible	Cartridge	H	30-800	3	—	—	YES②	YES	YES	—
	Non-Fusible	—	—	30-800	3	—	—	YES②	YES	YES	—
Receptacle	Fusible	Cartridge	H	30-100	3	—	—	YES	—	YES	—
	Non-Fusible	—	—	60	3	—	—	YES	—	YES	—
Non-Metallic	Fusible	Cartridge	H	30-200	3	—	—	—	—	—	YES
	Non-Fusible	—	—	30-200	3	—	—	—	—	—	YES

① Both galvanized steel and polymeric (non-metallic).

② NEMA Type 12 enclosures (30-200 amperes) can be field modified to meet NEMA Type 3R

rainproof requirements when a factory provided drain screw is removed.

Air Conditioning Disconnects



Specially designed as disconnects for light duty air conditioning and heat pump applications.

- 10,000 amperes rms symmetrical interrupting rating.
- Horsepower rated.
- Available with fusible or non-fusible pullout devices (240 Vac) or a molded case switch (120/240 Vac).
- 30 and 60 amperes (fusible pullout), 60 amperes (non-fusible pullout and molded case switch).
- Class H fuse clips provided on fusible pullout devices.

- Heavy duty construction. High strength metal enclosure with welded and riveted construction; or a rugged polymer with high impact UV resistant features.
- Swing-up cover remains in place when in the open position. Includes provision for padlocking.
- Two-position pullout provides a safety feature since the protective shield cannot be removed when the pullout is in the ON position. When in the OFF position, the shield can be removed to provide access to the fuses.

General Duty



For residential and commercial applications. Suitable for light duty motor circuits and service entrance.

- 30 through 600 amperes.
- For use on systems capable of delivering up to 10,000 rms (symmetrical fault current).*
- Suitable for service entrance applications unless otherwise noted.

- 200-600 amperes features K-series design.
- Horsepower rated.
- Fusible and non-fusible switches. One-pole S/N through four-wire; 120/240, and 240 Vac.
- Ample wire bending space provides for easier installation.

* Note: With class R fuses 100-600A switches may be used on systems capable of delivering 100,000 rms.

Heavy Duty



For heavy commercial and industrial applications where reliable performance and service continuity are critical.

- 30 through 1200 amperes.
- 600 Vac, 600 Vdc maximum.
- May be rated up to 100,000 rms symmetrical when used with Class J or R fuses; and the 400 to 1200 ampere switches are rated at 200,000 rms symmetrical when used with Class J, L, or R fuses.
- Horsepower rated.
- Suitable for service entrance use.

- Visible double break rotary blade mechanism. Two points of contact provide a positive open and close, easier operation, and also help prevent contact burning for longer contact life.
- Triple padlocking capability. Personnel safety feature since the large hasp can accommodate up to three 3/8-inch shank locks. Cabinet door can be further padlocked at the top and bottom.
- Interlocking mechanism. Door cannot be opened when the handle is in the ON position. Built-in defaeter mechanism provides for user access when necessary.

Selection Guide

6-Pole Motor Circuit



A compact safety switch that's ideal for use in heavy industry...when an "in sight" disconnecting means is required for two-speed motors that are remote from their motor control devices.

- 600 Vac, 250 Vdc maximum.
- 30 through 200 amperes.
- Fusible or non-fusible.
- Trunk-type latches keep the cover tightly closed and a neoprene gasket seals out moisture and dust from the switch assembly.

- Visible double break rotary blade mechanism. Two points of contact provide a positive open and close, easier operation, and also help prevent contact burning for longer contact life.
- Clear line shield protection.
- Built-in fuse pullers.
- Clearly visible handle.
- Triple padlocking capability. Cabinet door can be further padlocked at the top and bottom.

Heavy Duty Double Throw



Used to transfer service from a normal power source to an alternate source...or to switch from one load circuit to another.

- Recommended for systems where the available fault current does not exceed 100,000 rms symmetrical.
- 30 through 800 ampere switches are horsepower rated.
- 600 Vac, 250 Vdc maximum.
- Also suitable for use on systems capable of delivering 100,000 rms symmetrical fault current when used with Class J, R, or T fuses.
- Fusible or non-fusible.
- Load break rated and approved for service entrance.
- Wiring configuration from factory allows a single load to be supplied by a normal or alternate source. Can be field modified to allow two loads to be alternately supplied by a single power source.
- Non-fusible double throw switch can be used to feed a single throw fusible switch, the normal method to provide manual transfer from one power source to another in 800 ampere and larger switches.

- Ample wire bending space provides for easier installation.
- Visible double break rotary blade mechanism. Two points of contact provide a positive open and close, easier operation, and also help prevent contact burning for longer contact life.
- Triple padlocking capability. Personnel safety feature since the large hasp can accommodate up to three 3/8-inch shank locks.
- Clearly visible handle. The position (ON or OFF) can be clearly seen from a distance.
- Additional locking capability. Cabinet door can be further padlocked at the top and bottom.
- Clear line shield protects against accidental contact with energized parts. Probe holes enable the user to test if the line side is energized without removing the shield.
- Tangential knockouts on sides, top, and bottom. Enables any size of conduit to be mounted close to the wall, providing for cable installation closer to the wall and a neat appearance.

Enclosed Rotary



Provide users with the ability to lock directly wired motor loads in the OFF position to comply with new OSHA lockout/tagout regulations. Also for machine applications that require compact, economical disconnect switches.

- Meets NEC article 430 requirements for a separate disconnect means within sight of all motor loads.
- Padlockable in the OFF position (up to three padlocks) to meet OSHA lockout requirements.

- Available in 40, 80, and 100 ampere ratings.
- 600 Vac, three- and four-pole non-fusible device.
- Rated at highest available Hp rating (at 480 Vac, 40A-20 Hp, 80A-40 Hp, 100A-50 Hp).
- Rated for making and breaking loads.
- Accepts auxiliary contacts. Capability to signal PLC controllers.
- Ground lug connection provided.

New EnviroLine



Cutler-Hammer is introducing a new line of safety switches designed for your special application and/or extreme environmental conditions.

- **All Stainless Steel Switch** – primarily for use in the meatpacking and food processing industries or any application where water is frequently used to hose down equipment. In addition to the stainless steel NEMA 4X enclosure, the interior mechanism, back pan, and springs are all stainless steel. Ratings for these Heavy Duty switches are 30-400 amperes, 240-600 Vac, available as fusible and non-fusible switches.
- **Window Switches** – These switches are available with either an upper window over the switch contacts or a lower window over the fuse block. The upper window provides visual verification of ON/OFF status. The lower window switch allows for visual verification of fuse status if used in conjunction with Littelfuse, Inc fuses with blown fuse indicator. Ratings are 30-800 amperes, 240-600 Vac, fusible and non-fusible. Available in NEMA 12/3R, 4X stainless steel enclosures.

- **Receptacle Switches** – These Heavy Duty Switches are pre-wired and interlocked to polarized receptacles for three-phase, three-wire, grounded type power plugs. These are used for portable power applications such as welders, infrared ovens, batch feeders, conveyors, truck and marine docks. Receptacles are interlocked to handle mechanisms so that power plugs may not be inserted or removed when the switch is in the ON position unless noted otherwise. Ratings are 30-100 amperes, 600 Vac, NEMA 12, 4X stainless steel enclosures.
- **Non-Metallic Switch** – This switch has a KRYDON™ enclosure. This is a compression molded fiberglass reinforced polyester enclosure, which is capable of withstanding almost any corrosive environment. Ratings are 30-200 amperes, 240-600 Vac, fusible and non-fusible. Enclosure is NEMA 4X rated.



Catalog Numbering System, Features

Safety Switch Catalog Numbering System
Does not apply to Air Conditioning Disconnects.

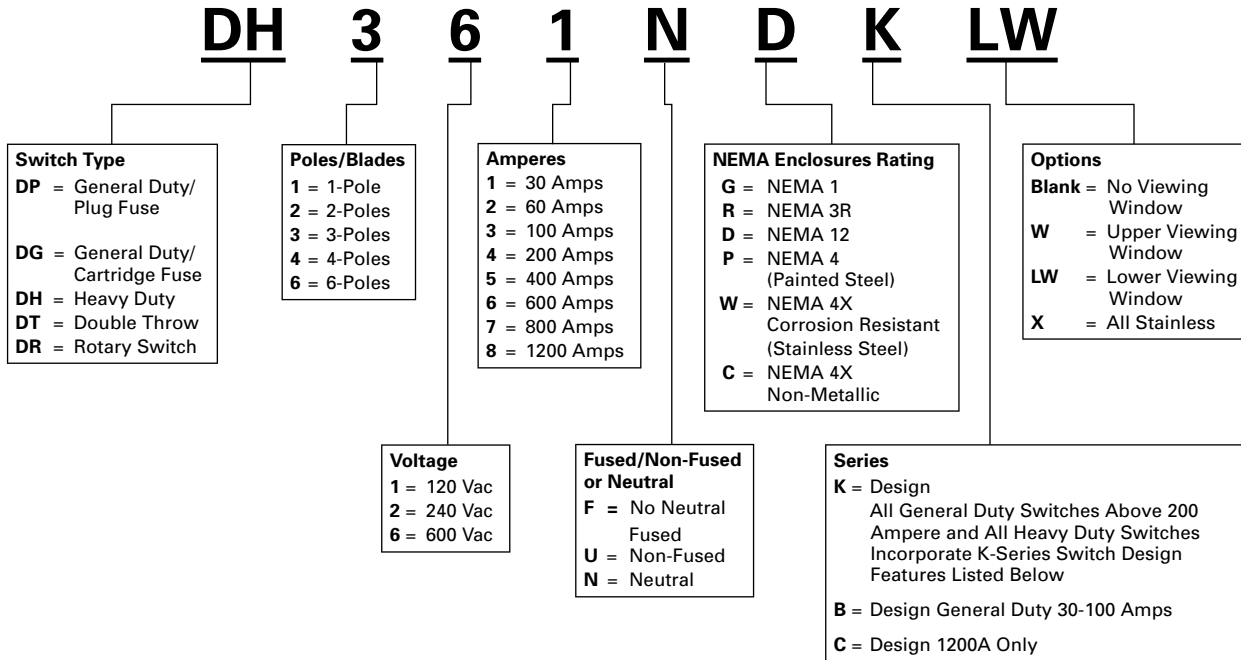

All General Duty Switches Above 200 Ampere and All Heavy Duty Switches Incorporate These K-Series Switch Design Features



Visible Double Break Rotary Blade Mechanism

Two points of contact provide a positive open and close, easier operation, and also help prevent contact burning for longer contact life.



Clearly Visible Handle

The position (ON or OFF) can be clearly seen from a distance and the length provides for easy operation.



Interlocking Mechanism

Door cannot be opened when the handle is in the ON position. Defeater mechanism provides for user access when necessary.



Clear Line Shield

Protects against accidental contact with energized parts. Probe holes enable the user to test if the line side is energized without removing the shield.



Triple Padlocking Capability

Personnel safety feature since the large hasp can accommodate up to three 3/8-inch shank locks.



Tangential Knockouts

An ample number are provided on the top, bottom, and sides of both NEMA Types 1 and 3R enclosures.



Built-In Fuse Pullers (NEMA 12 and 4X Only)

Provides easy removal of fuses.

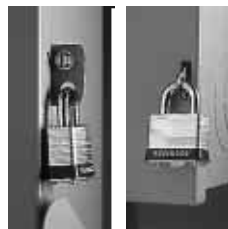

Additional Locking Capability

Cabinet door can be further padlocked at the top and bottom.



Bolt-On Hub Kits

For Switches in a NEMA Type 3R, 12, 4, 4X enclosure.



Accessories

Description	Catalog Number
Neutral Kits/Ground Kits 200A DG, DH (NEMA 1, 3R Enclosures) 30-60A DH 100A DH 200A DH (NEMA 4X, 12 Enclosures) 1200A DH 400A DG, DH 600A DG, DH 400-600A Fusible DT 30-100A DT 200 A DT 400A Non-Fusible DT 600 Non-Fusible DT	DG200NK DH030NK DH100NK DH200NK DS1200NC DS400NK DS600NK DS800NK DT100NK DT200NK DT400NK DT600NK
Ground Lug Kits 30-100A DG, DH, DT 200A DG, DH, DT 400-600A DG, 400-800A DH, 400-800A DT	DS100GK DS200GK DS468GK
Control Pole Kit 400-600A DG, 30-800A DH, 30-200A DT	DS16CP
Electrical Interlock Kits All Switches (except 30-100A DG, 1200A DH) 2NO/2NC All Switches (except 30-100A DG, 1200A DH) 2NO/2NC 1200 A DH 2NO/2NC	DS200EK1 DS200EK2 DS1200EK2
Copper Lug Kits 30A DH, DT (order one kit for 3 poles) 60A DH, DT (order one kit for 3 poles) 100A DH, DT (order one kit for 3 poles) 200A DH (order one kit for 3 poles) 400A DG, DH (order one kit for each pole) 600A DG, DH (order one kit for each pole)	DS16CL DS26CL DS36CL DS46CL DS56CL DS66CL
Crimp Lug Pad Kit 400-600A DG, DH (order one kit for 3 poles) 800A DG, DH (order one kit for each pole) 400-800A Neutral DG, DH (order one kit per switch)	DS56CK DS76CK DS800CNK
Special Lug Kit (750 kcmil) 600A DG, DH (order one kit for each pole)	DS750KL
Fuse Puller Kits 30-60A DH (order one kit for 3 poles) 60A DH (4 pole switch only) 100A DH (order one kit for 3 poles) 200A DH (order one kit for 3 poles)	DS30FP DS60FP DS100FP DS200FP
"J" Fuse Adapter Kits 60A 240V DH, DT (order one kit for 3 poles) 60A 600V DH, DT (order one kit for each pole) 400A 600V DT (order one kit for 6 poles) 600A 240-600V DH only	DS22JK DS26JK DT400JK DS600JK
"R" Fuse Adapter Kits 30-60A DG 30A 240V DH, DT 30A 600V DH, DT, 60A 240V DH, DT 60A 600V DH, DT 100A 240-600V DH, DT 200A 240-600V DH, DT 400A 240-600V DH, DT 600A 240-600V DH, DT	DG32RK DS12FK DS16FK DS26FK DS36FK DS46FK DS56FK DS66FK
"T" Fuse Adapter Kits 200A 240V DH (order one kit for 3 poles) 200A 600V DH (order one kit for 3 poles) 400A 240V DG, DH (order one kit for each pole) 400A 600V DG, DH (order one kit for each pole) 600A 240V DG, DH (order one kit for each pole) 600A 600V DG, DH (order one kit for each pole) 800A 240V DG, DH (order one kit for each pole) 800A 600V DG, DH (order one kit for each pole)	DS426TK DS466TK DS526TK DS566TK DS626TK DS666TK DS726TK DS766TK
Auxiliary Contacts for Rotary Switches	C362AC1 C362AC3 C362AC5



DS12FK



DS426TK

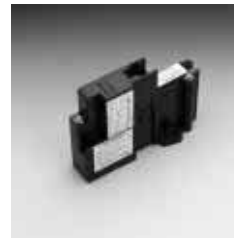

DS16CP



DS100GK



DS200EK1



DH030NK



Accessories, Hubs, Lug Data

Hubs

Plate Type Hubs

For NEMA Type 3R Enclosures (Up to 200 Amperes)

Group 1 General Duty, Heavy Duty, Double Throw Through 100A			Group 2 General Duty, Heavy Duty, Double Throw – 200A		
Conduit Size		Catalog Number	Conduit Size		Catalog Number
Inches	mm		Inches	mm	
3/4	19.0	DS075H1	2	50.8	DS200H2
1	25.4		2-1/2	63.5	
1-1/4	31.8	DS125H1	3	76.2	DS250H2
1-1/2	38.1	DS150H1			DS300H2
2	50.8	DS200H1			

Catalog Number DS900AK Adapter Kit – Permits Installation of Group 1 Hubs on 200 Ampere Type General Duty, Heavy Duty and Double Throw Switches



DS075H1

Myers Type Hubs

NEMA Type 3R (400 Amperes and Above)
NEMA Types 4, 4X (Stainless Steel), 12

Conduit Size		Catalog Number
Inches	mm	
1/2	12.7	DS050MH
3/4	19.0	DS075MH
1	25.4	DS100MH
1-1/4	31.8	DS125MH
1-1/2	38.1	DS150MH
2	50.8	DS200MH
2-1/2	63.5	DS250MH
3	76.2	DS300MH
3-1/2	88.9	DS350MH
4	101.6	DS400MH
5	127.0	DS500MH

C401 Hubs

For NEMA 4X Non-Metallic Enclosures Only

Conduit Size		Conduit Hub		Ground Bushing ^①	
Inches	mm	Catalog Number	Catalog Number	Catalog Number	Catalog Number
3/4	19.0	C401AC2	C401CC2		
1	25.4	C401AC3	C401CC3		
1-1/4	31.8	C401AC4	C401CC4		
1-1/2	38.1	C401AC5	C401CC5		
2	50.8	C401AC6	C401CC6		
2-1/2	63.5	C401AC7	C401CC7		
3	76.2	C401AC8	C401CC8		

Standard Lug Capacities

Ampere Rating	Minimum Wire Size	Maximum Wire Size	Type Wire
30A DP	#14	#8	Cu
30A DG	#14	#6	Al/Cu
30A DH, DT	#14	#2	Al/Cu
60A DG, DH, DT	#14	#2	Al/Cu
100A DG	#14	#1	Al/Cu
100A DH, DT	#14	#1/0	Al/Cu
200A DG, DT	#6	250 kcmil	Al/Cu
200A DH Type 1 & 3R	#6	250 kcmil	Al/Cu
200A DH Type 4 & 12	#6	300 kcmil	Al/Cu
400A DG, DH, DT	(2) #1/0 or (1) #1/0	(2) 300 kcmil or (1) 750 kcmil	Al/Cu
600A DG	(2) #2	(2) 600 kcmil	Al/Cu
600A DH	(2) #2	(2) 600 kcmil	Al/Cu
600A DT (Fusible)	(2) #2	(2) 600 kcmil	Al/Cu
600A DT (Non-Fusible)	(2) #250	(2) 500 kcmil	Al/Cu
800A DH	(4) #1/0	(4) 750 kcmil	Al/Cu
800A DT	(3) #250	(3) 500 kcmil	Al/Cu
1200DH	(4) #1/0	(4) 750 kcmil	Al/Cu

① Grounding bushings are required when metallic conduit is used for a ground conductor.

Dimensions

General Duty, Non-Fusible, 240V, 3-Pole, Single Throw

Ampere Rating	NEMA 1			NEMA 3R		
	W	H	D	W	H	D
30	6-1/16	7-17/32	6-23/32	6-3/4	9-1/8	6-3/4
60	8-1/8	12-13/16	8-7/8	8-1/8	12-11/16	8-7/8
100	8-1/2	17-1/2	8-3/4	8-1/2	17-3/8	8-3/4
200	16	25-1/4	11-1/4	16	25-1/2	11-1/4
400	23	54-1/2	12-5/8	23	54-1/4	12-5/8
600	24	59-3/4	14-1/4	24	59-3/4	14-1/4

General Duty, Fusible, 240V, 3-Pole Solid Neutral, Single Throw

Ampere Rating	NEMA 1			NEMA 3R		
	W	H	D	W	H	D
30	6-1/16	7-1/2	6-3/4	6-3/4	9-1/8	6-3/4
60	8-1/8	12-13/16	8-7/8	8-1/8	12-11/16	8-7/8
100	8-1/2	17-1/2	8-3/4	8-1/2	17-3/8	8-3/4
200	16	24-3/4	11-1/4	16	25-1/2	11-1/4
400	23	53-7/8	12-5/8	23	54-1/4	12-5/8
600	24	59-3/8	14-1/4	24	59-3/4	14-1/4

Dimensions (in inches) are for estimating purposes only.

Figure 1

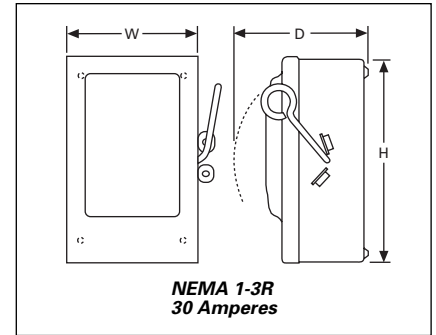

Figure 2

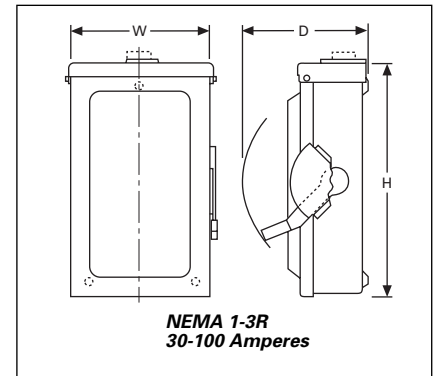
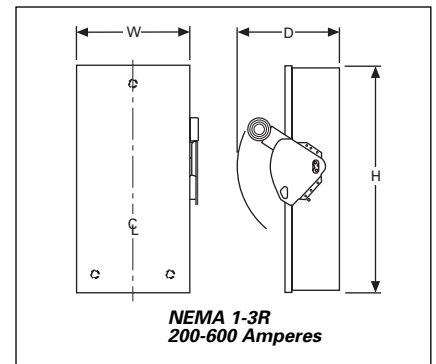

Figure 3



Dimensions

Heavy Duty, Non-Fusible, 600V, 3-Pole, Single Throw

Ampere Rating	NEMA 1, 3R			NEMA 12, 4XSS		
	W	H	D	W	H	D
30	8-1/8	15-7/8	10	8-1/8	12-1/8	10
60	8-1/8	15-7/8	10	8-1/8	12-1/8	10
100	11-1/8	21-11/16	10	11-1/8	24	10-1/4
200	16	27-5/8	11-1/4	16	34-3/8	11-1/2
400	23	53-7/8	12-5/8	23	57-5/8	12-5/8
600	24	59-3/8	14-1/4	24	63	14-1/4
800	25-3/8	68	14-1/4	25-3/8	71-3/4	14-1/4
1200	31-3/16	52-5/16	17-1/2	-	-	-

Heavy Duty, Fusible, 240 and 600V, 3-Pole Solid Neutral, Single Throw

Ampere Rating	NEMA 1, 3R			NEMA 12, 4XSS		
	W	H	D	W	H	D
30	8-1/8	15-7/8	10	8-1/8	17-7/8	10
60	8-1/8	15-7/8	10	8-1/8	17-7/8	10
100	11-1/8	21-11/16	10	11-1/8	24	10-1/4
200	16	27-5/8	11-1/4	16	34-3/8	11-1/2
400	23	53-7/8	12-5/8	23	57-5/8	12-5/8
600	24	59-3/8	14-1/4	25-3/8	71-3/4	14-1/4
800	25-3/8	68	14-1/4	25-3/8	71-3/4	14-1/4
1200	31-3/16	65-1/2	17-1/2	-	-	-

Dimensions (in inches) are for estimating purposes only.

Figure 1

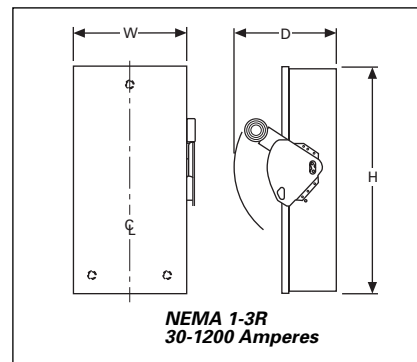
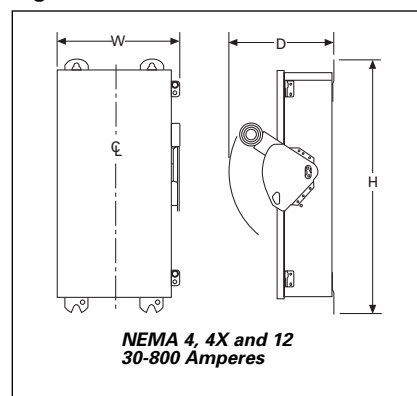

Figure 2



Technical Data

Maximum Horsepower Ratings

General Duty, Fusible and Non-Fusible, 240V With Time Delay Fuses

Ampere Rating	1 Phase AC	3 Phase AC
30	3	7-1/2
60	10	15
100	15	30
200	15	50
400	—	125
600	—	200

Heavy Duty, Fusible, 240V With Time Delay Fuses

Ampere Rating	1 Phase AC	3 Phase AC
30	3	7-1/2
60	10	15
100	15	30
200	15	60
400	—	125
600	—	200
800	—	250

Heavy Duty, Fusible and Non-Fusible, 480V With Time Delay Fuses

Ampere Rating	1 Phase AC	3 Phase AC
30	7-1/2	15
60	20	30
100	30	60
200	50	125
400	—	250
600	—	400
800	—	500

Heavy Duty, Fusible and Non-Fusible, 600V With Time Delay Fuses

Ampere Rating	1 Phase AC	3 Phase AC
30	10	20
60	25	50
100	30	75
200	50	150
400	—	350
600	—	500
800	—	500



Typical Specifications

Typical Specifications**General Duty****General**

Furnish and install, where indicated, general duty type safety switches having the electrical characteristics, ratings and modifications shown on the drawings.

UL, Federal and NEMA Specifications

All switches shall be Underwriters Laboratories Inc., File No. E5239 listed, comply with UL98 and meet NEMA KS-1 specifications.

Qualifications

- A. For equipment specified herein, the manufacturer shall be ISO 9000 certified.
- B. The manufacturer of this equipment shall have produced similar electrical equipment for a minimum period of seven (7) years.

Manufacturer

- A. Cutler-Hammer.

Ratings

- A. Safety switches shall be rated for a maximum of 240 Volts Ac, single-pole through 3-pole with optional solid neutral.
- B. Switches shall have short circuit ratings as shown on the drawings or as herein scheduled, but not less than 100,000 amperes RMS (symmetrical fault current).
- C. Ampere ratings of 30 through 600.
- D. Switches shall be horsepower rated.
- E. Suitable for service entrance applications unless otherwise noted.
- F. Fusible and non-fusible switches.

Construction

- A. Safety switch design must have quick-make/quick-break operating mechanism.
- B. Double-break rotary action shaft and switchblade shall be manufactured as one common component. Pivot point is not acceptable.

- C. The fuses will be easy to access. Bail Handle is not acceptable.
- D. NEMA 3R will be a side opening cover.

Wiring/Termination

- A. All wire connectors and terminals shall be of the anti-turn solderless type and shall be suitable for copper and aluminum wire of the sizes indicated.
- B. All safety switches where marked shall be suitable for use with 60/75 degree C rated wire.
- C. All switches shall conform to the latest NEC wire bending space requirements.

Enclosure

- A. Safety switch shall have NEMA 1 general purpose or NEMA 3R rainproof enclosures as indicated on the drawings.
- B. The cover shall have door interlock to prevent the switch being opened in the "ON" position.
- C. The handle will be red and easily recognizable, and is padlockable in the "OFF" position.
- D. The door shall have a one-piece lockable hasp.
- E. The side, top and bottom sides shall have tangential knockouts.
- F. The back of enclosure shall have concentric knockouts.

Finish

- A. Enclosure shall be phosphated and finished with a medium light gray ASA 61 enamel. The finish paint shall be of a type to which field applied paint will adhere.

Factory Testing

- A. The standard factory tests shall be performed on the equipment provided under this section. All tests shall be in accordance with the latest version of UL and NEMA.

Heavy Duty**General**

Furnish and install, where indicated, heavy duty type safety switches having the electrical characteristics, ratings and modifications shown on the drawings.

UL, Federal and NEMA Specifications

All switches shall be listed with Underwriters Laboratories Inc., under File No. E5239, comply with UL98 and meet NEMA KS-1 specifications and previous Federal Specification WS-865c Type HD.

Qualifications

- A. For equipment specified herein, the manufacturer shall be ISO 9000 certified.
- B. The manufacturer of this equipment shall have produced similar electrical equipment for a minimum period of seven (7) years.

Manufacturer

- A. Cutler-Hammer.

Ratings

- A. Safety switches shall be rated for 240 Volts Ac, Dc or 600 Volts Ac 2-pole through 6-pole.
- B. Switches shall have short circuit ratings as shown on the drawings or as herein scheduled, but not less than 100,000 amperes RMS (at 600 volt) with Class J or R fuses. The 400 to 1200 ampere switches are rated 200,000 RMS (at 480 volt) when used with Class J, L, or R fuses.
- C. Ampere ratings of 30 through 1200.
- D. Switches shall be horsepower rated.
- E. Suitable for service entrance applications unless otherwise noted.
- F. Fusible and Non-fusible switches.

Typical Specifications

Construction

- A. Safety switch design must have quick-make/quick-break operating mechanism.
- B. Switch shall have deionizing arc chutes to confine and suppress the arcs produced by contacts under load.
- C. Double-break rotary action shaft and switchblade shall be manufactured as one common component. Pivot point is not acceptable.
- D. Switches shall have built-in fuse pullers for type 4 and 12.
- E. Switch shall have clear line shields to prevent accidental contact with line terminals.

Wiring/Termination

- A. All wire connectors and terminals shall be of the anti-turn solderless type and shall be suitable for copper and aluminum wire of the sizes indicated.
- B. All safety switches where marked shall be suitable for use with 60/75 degree C rated wire.
- C. All switches shall conform to the latest NEC wire bending space requirements.

Enclosure

- A. Safety switch shall have NEMA 1 general purpose, NEMA 3R rain-proof, NEMA 12 dust-tight, NEMA 4 painted steel, NEMA 4X stainless steel or NEMA 4X non-metallic enclosures as indicated on the drawings.
- B. The cover shall have door interlock to prevent the switch being opened in the "ON" position.
- C. Defeat mechanism for door interlock must be front accessible.
- D. The handle will be red and easily recognizable, and be pad-lockable in the "OFF" position.
- E. The door shall have a one-piece lockable hasp.

- F. The side, top and bottom sides shall have tangential knockouts.
- G. The back of enclosure shall have concentric knockouts.
- H. Enclosures shall be predrilled to accommodate field installable neutral.

Finish

- A. Enclosure shall be phosphated and finished with a medium light gray ASA 61 enamel. The finish paint shall be of a type to which field applied paint will adhere.

Factory Testing

- A. The standard factory tests shall be performed on the equipment provided under this section. All tests shall be in accordance with the latest version of UL and NEMA.

Double Throw

General

Furnish and install for use as a transfer switch where indicated double-throw switches having the electrical characteristics, ratings and modifications shown on the drawings.

UL, Federal and NEMA Specifications

All switches shall be listed with Underwriters Laboratories Inc., under File No. E5239, comply with UL98 and meet NEMA KS-1 specifications and previous Federal Specification WS-865c Type HD.

Qualifications

- A. For equipment specified herein, the manufacturer shall be ISO 9000 certified.
- B. The manufacturer of this equipment shall have produced similar electrical equipment for a minimum period of seven (7) years.

Manufacturer

- A. Cutler-Hammer.

Ratings

- A. Safety switches shall be rated for 240 Volts Ac, Dc or 600 Volts Ac 2-pole through 6-pole.

- B. Switches shall be suited for use on systems where the available fault current of 100,000 amperes RMS symmetrical when used with Class J, R, or T fuses.
- C. Ampere ratings of 30 through 800.
- D. Switches shall be horsepower rated.
- E. Load break rated and approved for service entrance applications unless otherwise noted.
- F. Fusible and non-fusible switches.

Construction

- A. Safety switch design must have quick-make/quick-break operating mechanism with two points of contact.
- B. Switch shall have deionizing arc chutes to confine and suppress the arcs produced by contacts opening under load.
- C. Double-break rotary action shaft and switchblade shall be manufactured as one common component. Pivot point is not acceptable.
- D. Switch shall have clear line shields to prevent accidental contact with line terminals.

Wiring/Termination

- A. Wiring configuration from the factory shall allow a single load to be supplied by a normal or alternate source. It can be field modified to allow two loads to be alternately supplied by a single power source.
- B. All wire connectors and terminals shall be of the anti-turn solderless type and shall be suitable for copper and aluminum wire of the sizes indicated.
- C. All safety switches where marked shall be suitable for use with 60/75 degree C rated wire.
- D. All switches shall conform to the latest NEC wire bending space requirements.

Typical Specifications

Enclosure

- A. Safety switch shall have NEMA 1 general purpose, NEMA 3R rain-proof, or NEMA 4X stainless steel enclosures as indicated on the drawings.
- B. The handle will be red and easily recognizable, and have triple padlocking capability.
- C. The door shall have a one-piece lockable hasp.
- D. The side, top and bottom sides shall have tangential knockouts.
- E. The back of enclosure shall have concentric knockouts.
- F. Enclosures shall be pre-drilled to accommodate field installable neutral.

Finish

- A. Enclosure shall be phosphated and finished with a medium light gray ASA 61 enamel. The finish paint shall be of a type to which field applied paint will adhere.

Factory Testing

- A. The standard factory tests shall be performed on the equipment provided under this section. All tests shall be in accordance with the latest version of UL and NEMA.

For a complete product specification in CSI format, see **Cutler-Hammer Product Specification Guide**, section 16441.

